

## 2000 SERIES

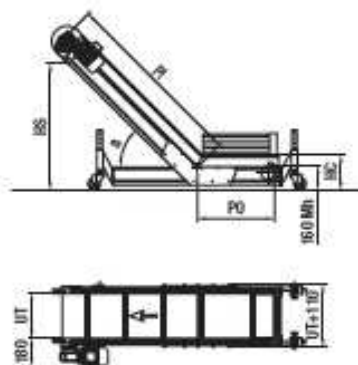

### P2400 – Technical Specification

<b>Description</b>	Horizontal to Incline Plastic Belt Conveyor
<b>Fix incline</b>	PT:30° - PQ:45° - PS:60°
<b>Frame</b>	6060 anodized extruded aluminium profile 117x25mm
<b>Joint profile</b>	6060 Extruded aluminium profile 46x27mm
<b>Belt sliding guides</b>	Nylon
<b>Sides</b>	PO: Anodized aluminium sides h70mm + 2 interchangeable sides h140mm PI: Anodized aluminium sides h70mm
<b>Legs</b>	Perforated zinc plated steel legs 35x35x300mm, vertical and horizontal adjustment
<b>End of legs</b>	Revolving wheels Ø 80mm
<b>Belt</b>	PP belt (125°C) or PA belt (165°C), light grey, equipped with 26mm high side walls that are integral part of the belt and move along with the belt
<b>Cleats</b>	PU black or white (FDA) / H=20/30/50mm / Pitch = 378mm (width 200÷500), 630mm (width 550÷1500)
<b>Traction</b>	Galvanized metal hexagonal drive shaft 27mm, PP cogwheels Z=8
<b>Drive</b>	Direct drive with torque limiter
<b>Asynchronous Motor</b>	3PH 4poli (1360rpm) IP55 with fan – 400Vac/50Hz
<b>Power</b>	0,18KW - 0,25KW - 0,37KW
<b>Gear box with permanent Lubrication / Speed</b>	1/30 13m/m - 1/60 7m/m - 1/100 4m/m
<b>Control Panel</b>	IP55, thermal overload protected motor starter (on/off), emergency button, five cores (5x1,5mm) cable length 3000mm flame-retardant



PL MACHINERY SERVICES & SALES LTD  
 UNIT A3/A4 BARTON INDUSTRIAL ESTATE, FALDO ROAD,  
 BARTON LE CLAY, BEDFORDSHIRE, MK45 4RP  
 TEL: 01582 883666 / EMAIL: [sales@plmachinery.com](mailto:sales@plmachinery.com)