



Model CPC320CSC2

PULL AND CUT WITH REPEATED ACCURACY AND PRECISION

Precisely pull and cut plastic and rubber tubings, rigid tubing, and custom profiles. Choose when you want close tolerances at high cutting speeds. Combination Puller/Cutters are available with your choice of puller sizes, cutter capacities and torque to meet your specific needs.

Positional accuracy of ± 0.10 millisecond for the price of a velocity controlled servo.

IMPROVED ACCESS FOR CLEANING

The CPC's cutter features a position-controlled servo motor that allows the units to achieve a park position repeatability of ± 0.1 millisecond.

The puller belt drive is a high-performance AC vector system that offers extremely good speed control, which can be further improved by using an optional single or dual servo motor. A variety of puller belt materials available from Conair can optimize performance for various types of extruded materials.

An option available on the Combination Puller/Cutter digitally controls the belt gap with the sensor. It sets the zero point for the belts when closed, and then measures the gap to three decimal places.

■ More torque and motor life

Eliminate maintenance while improving performance. Our unique in-line gear reducer improves torque values while reducing maintenance associated with belt and pulley designs.

■ All new operator control

The CPC features a user-friendly, 7-inch {178mm} touch screen with high visibility graphics and intuitive commands for controlling the puller and cutter. A large pop-up "soft" keypad makes recipe entry fast and easy.

■ Cutting capacity to 4 inches

The Combination Puller/Cutter can handle extrudates up to 4 inch {101.6 mm} diameter. The puller portion lets you choose belt widths from 3 to 4 inches {76.2 to 101.6 mm} and traction lengths to 26 inches {660.4 mm}. Options are available for cutting corrugated plastic.

■ Flexible cutters for speed or torque

Standard cutter models include precision 4:1 inline planetary gear reducer for enhanced cutting torque up to 750 RPM. Lower bushing models have an option for no planetary reducer, which allows flywheel operation up to 3000 RPM.

■ Available in wide size ranges

Choose from a variety of belt sizes and cutting capacities, as well as a range of speeds. Consult your Conair representative for the best model configuration for your needs.



FEATURES

Optimum eye-level monitoring

Controls are at eye-level and within easy reach.

Easy-access motor

Quick-remove cover for easy access to motor during maintenance.

Visible cutter head

Clear knife guard lets you view rotating cutter head, blade(s) during operation.

Built-in cleaning

Stainless steel blade lubrication tray cleans and lubricates the blade(s) with each pass, and the cutting chamber has a fitting for easy drainage.

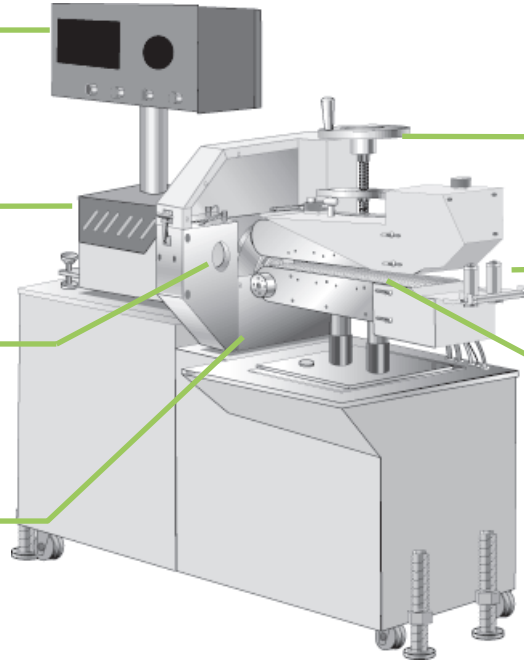

Controlled belt tension

Adjust belts and control tension on material by raising/lowering belts with an easy turn.

Centered, guided material

Adjustable rollers guide material into the belts.

Precise pulling

Opposing belts uniformly draw material through to the cutter.

Safety features include:

- Easy-to-reach Emergency and Stop buttons
- Polycarbonate knife guard
- Upper and lower belt guards
- Heavy-duty lockdown screws
- Electric eye and bracket for use with Endsense mode
- Optional puller enclosure

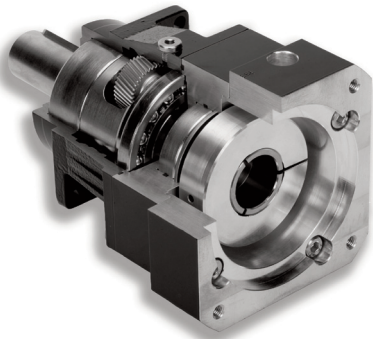

- **In-line gearbox reducer** lessens the maintenance required by traditional belt-and-pulley designs. The reducer improves torque performance, improves side load capabilities and extends the life of the servo motor. (Does not apply for L models.)

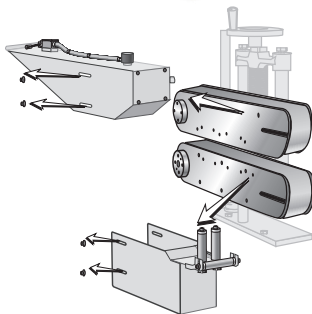

- **Upper and lower belt guards** protect the user and are easily removed when changing the belts.

- **Offset bushing bores** allow you to center parts on a 6 inch wide conveyor, making it easy to position the conveyor.

CPC MODELS

CONTROL

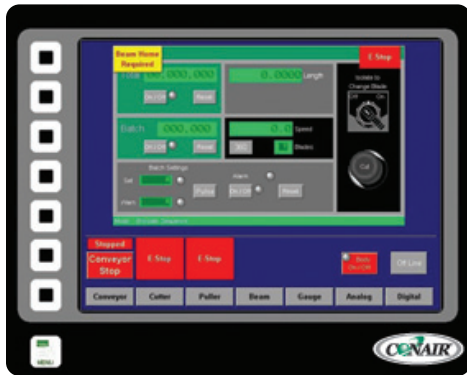

Standard touch screen features include:

- Full-color graphics
- Large easy-to-read display
- Selectable cutting modes, blade speed and Start/Stop functions
- Total access to vector or servo drives for tuning and service.



Digital Belt Gap Sensor

This option allows you to set the zero point for the belt gap, and then set and measure belt gap to three decimal places.

SPECIFICATIONS

SPECIFICATION NOTES

* Optional

CSC2L cutters do not come with planetary reducers, allowing flywheel operation up to 3000 RPM.

Option exists for dual servo pullers for high speeds at minimal backlash.

Specifications may change without notice. Check with a Conair representative for the most current information.

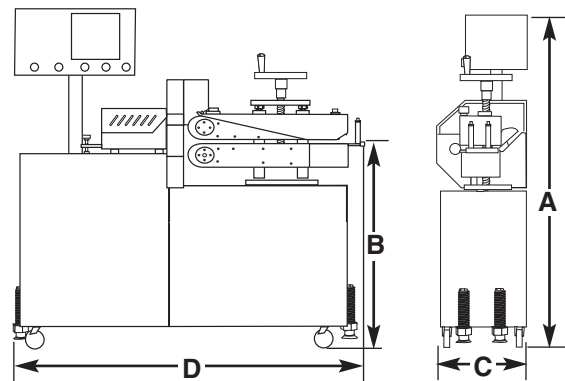

MODELS	CPC320-CSC2L	CPC320-CSC2	CPC320-CSC3						
Performance characteristics									
Extrudate capacity inches {mm} dia.	1.25 {32}	2 {51}	3 {76}						
CSC cutter motor (servo) Hp {kW}	3.25 {2.4}	3.25 {2.4}	3.25 {2.4}						
High-torque cutter motor (servo)* Hp {kW}	N/A	3.8 {2.8}	3.8 {2.8}						
CPC puller motor Hp {kW}	1.0 {0.75}	1.0 {0.75}	1.0 {0.75}						
High-torque puller motor* Hp {kW}	1.5 {1.1}*	1.5 {1.1}*	1.5 {1.1}*						
Servo puller motor* Hp {kW}	3.25 {2.4}*	3.25 {2.4}*	3.25 {2.4}*						
Reducer ratios available	5:1, 10:1, 20:1, 40:1								
Dimensions inches {mm}									
A - Height	66.6 {1691}	66.6 {1691}	66.6 {1691}						
B - Height to centerline, ±2 {±50.8}	42.0 {1067}	42.0 {1067}	42.0 {1067}						
C - Width	26.6 {676}	26.6 {676}	26.6 {676}						
D - Length	74.0 {1880}	74.0 {1880}	74.0 {1880}						
Belt width ±3/8 {±9.5}	3.0 {76}	3.0 {76}	3.0 {76}						
Belt traction length	20.0 {508}	20.0 {508}	20.0 {508}						
Feed opening	4.0 {102}	4.0 {102}	4.0 {102}						
Weight lb {kg}									
Installed	1200 {545}	1200 {545}	1200 {545}						
Shipping	1300 {590}	1300 {590}	1300 {590}						
Electrical requirements full load amps									
Puller motor type	Standard	High-torque	Servo	Standard	High-torque	Servo	Standard	High-torque	Servo
230V/3 phase/60Hz FLA	15.2	17	19.6	15.2	17	19.6	15.2	17	19.6
460V/3 phase/60Hz (Std.) FLA	9.3	10.2	12	9.3	10.2	12	9.3	10.2	12



SPECIFICATIONS

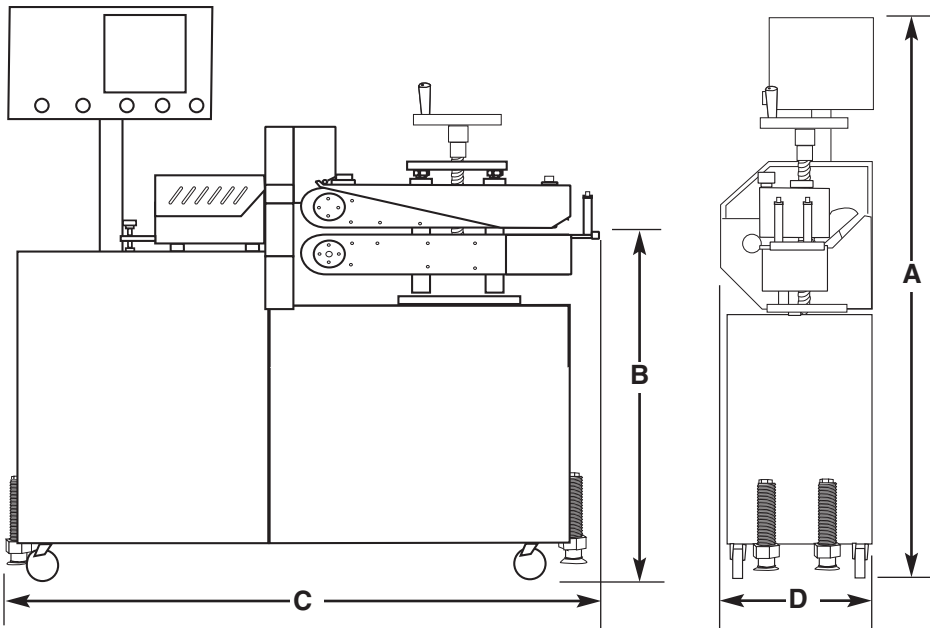

CUTTER HEADS
 Standard: Aluminum 2-position
 Optional: Stainless Steel 2-position
 Optional: Stainless Steel HD 2-position

SPECIFICATION NOTES
 * Optional
 CSC2L cutters do not come with planetary reducers, allowing flywheel operation up to 3000 RPM
 Option exists for dual servo pullers for high speeds at minimal backlash.
 Specifications may change without notice. Check with a Conair representative for the most current information.

MODELS	CPC426-CSC2L	CPC426-CSC2	CPC426-CSC3	CPC426-CSC4								
Performance characteristics												
Extrudate capacity in. {mm} dia.	1.25 {32}	2 {51}	3 {76}	4 {102}								
CSC cutter motor (servo) Hp {kW}	3.25 {2.42}	3.25 {2.42}	3.25 {2.42}	N/A								
High-torque cutter motor (servo)* Hp {kW}	4.4 {3.3}	4.4 {3.3}	4.4 {3.3}	4.4 {3.3}								
CPC puller motor Hp {kW}	1.5 {1.1}	1.5 {1.1}	1.5 {1.1}	1.5 {1.1}								
High-torque puller motor* Hp {kW}	2.0 {1.5}*	2.0 {1.5}*	2.0 {1.5}*	2.0 {1.5}*								
Servo puller motor* Hp {kW}	3.25 {2.4}*	3.25 {2.4}*	3.25 {2.4}*	3.25 {2.4}*								
Reducer ratio options	5:1, 10:1, 20:1, 40:1											
Dimensions in. {mm}												
A - Height	66.6 {1691}	66.6 {1691}	66.6 {1691}	66.6 {1691}								
B - Height to centerline, ±2 {±50.8}	42.0 {1067}	42.0 {1067}	42.0 {1067}	42.0 {1067}								
C - Width	26.6 {676}	26.6 {676}	26.6 {676}	26.6 {676}								
D - Length	74.0 {1880}	74.0 {1880}	80.0 {2032}	80.0 {2032}								
Belt width ±3/8 {±9.5}	4.0 {102}	4.0 {102}	4.0 {102}	4.0 {102}								
Belt traction length	26.0 {660}	26.0 {660}	26.0 {660}	26.0 {660}								
Feed opening	5.0 {127}	5.0 {127}	5.0 {127}	5.0 {127}								
Weight lb {kg}												
Installed	1350 {613}	1350 {613}	1350 {613}	1350 {613}								
Shipping	1450 {658}	1450 {658}	1450 {658}	1450 {658}								
Electrical requirements												
Puller drive type	Standard	High-torque	Servo	Standard	High-torque	Servo	Standard	High-torque	Servo	Standard	High-torque	Servo
230V/3 phase/60Hz FLA	17	19	19.6	17	19	19.6	17	19	19.6	17	19	19.6
460V/3 phase/60Hz (Std.) FLA	10.2	11.4	12	10.2	11.4	12	10.2	11.4	12	10.2	11.4	12

