

ASC SERIES

COMPRESSED AIR VENTURI LOADER



STANDARD FEATURES:

- Stainless steel body
- Paper cartridge filter
- Level control capacitive sensor
- Venturi suction probe & anti-static hose

MICROPROCESSOR CONTROL: CS

- Programmable loading times
- Material shortage alarm

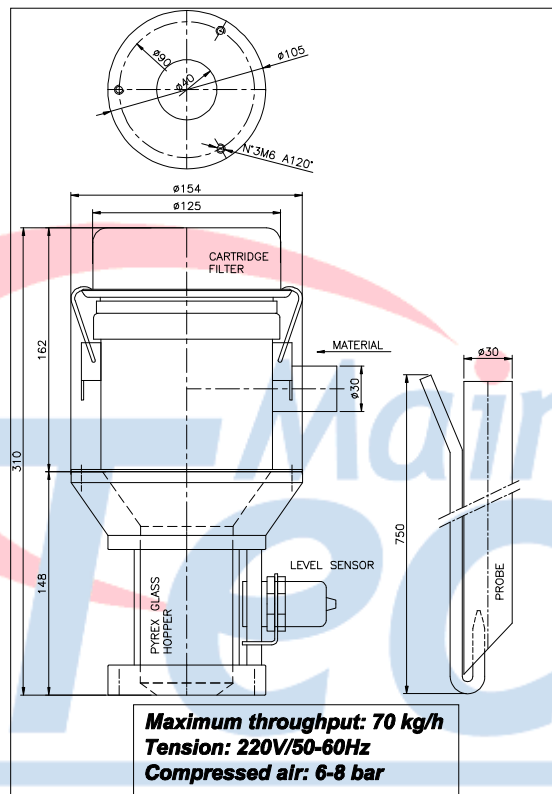

PL MACHINERY SERVICES & SALES LTD
UNIT A3/A4 BARTON INDUSTRIAL ESTATE, FALDO ROAD,
BARTON LE CLAY, BEDFORDSHIRE, MK45 4RP
TEL: 01582 883666 / EMAIL: sales@plmachinery.com