

1000 SERIES - C1200 INCLINE CONVEYOR

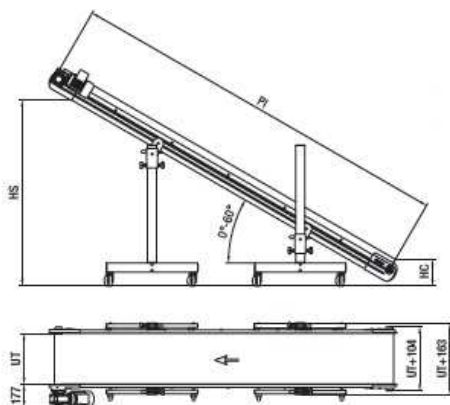

STANDARD TECHNICAL SPECIFICATIONS

Dimensions	PO: from 1000mm / to 7000mm (50mm increment) UT: from 190mm / to 790mm (50mm increment)
Frame	118x26mm anodised extruded aluminium profile with 10mm T-slots closed by black PVC profile; 40x40mm extruded aluminium joint profiles; Die cast aluminium alloy head supports
Intermediate metal plate	AISI430
Sidewalls	H60mm anodised extruded aluminium profile; On request: H100/160/210mm and H130/180mm 90° bend ed (for PC cover)
Stand supports	Die cast aluminium alloy hinges and clamps; 30x70XH900mm zinc plated steel legs with adjustable height every 30mm with "H" shape base; Ø80mm castors with brake (1 stand support only for conveyor length up to 2000mm);
Idle and drive rollers	Ø60mm extruded aluminium profile
Belt	Petrol green quadrangular pattern PVC, max temperature resistance 100°C in continuous, antistatic
Drive	Direct (left side)
Gear Motor	3 Phase – 400Vac/50Hz – 0.18Kw – asynchronous motor
Speed	3.2m/min.
Load	30kg
Control	IP55, thermal overload protected motor starter (on/off), emergency button, five cores (5x1.5mm) cable length 3000mm flame-retardant



PL MACHINERY SERVICES & SALES LTD
UNIT A3/A4 BARTON INDUSTRIAL ESTATE, FALDO ROAD,
BARTON LE CLAY, BEDFORDSHIRE, MK45 4RP

TEL: 01582 883666 / EMAIL: sales@plmachinery.com