

## 1000 SERIES - C1400 HORIZONTAL / INCLINE CONVEYOR

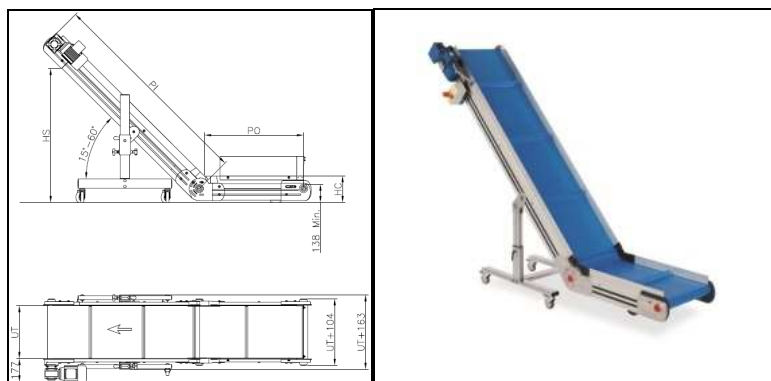

PN	PO	PI	UT	*HS min 15°	*HS max 60°
C1400 600+1200xUT	600	1200	da/from 190 a/to 640	250	900
C1400 600+1600xUT	600	1600	da/from 190 a/to 640	350	1250
C1400 700+2000xUT	700	2000	da/from 190 a/to 640	450	1600
*HC 200mm					

### STANDARD TECHNICAL SPECIFICATIONS

<b>Dimensions</b>	PO: from 500mm / to 3500mm (50mm increment) PI: from 800mm / to 3500mm (50mm increment) UT: from 190mm / to 640mm (50mm increment) PI incline range: from 15° / to 60° (7.5° increments)
<b>Frame</b>	118x26mm anodised extruded aluminium profile with 10mm T-slots closed by black PVC profile; 40x40mm extruded aluminium joint profile; Die cast aluminium alloy head supports and hinges
<b>Intermediate metal plate</b>	AlSi430
<b>Sidewalls</b>	PO: H60mm anodised extruded aluminium profile + H150mm (interchangeable right or left) + H210mm with PU flap (frontal); PI: H60mm anodised extruded aluminium profile; On request: H100/160/210mm and H130/180mm 90°bend ed (for PC cover)
<b>Stand supports</b>	Die cast aluminium alloy hinges and clamps; 30x70xH630mm zinc plated steel legs with adjustable height every 30mm with "H" shape base; Ø80mm castors with brake and shock absorber supports
<b>Idle and drive rollers</b>	Ø60mm extruded aluminium profile
<b>Belt</b>	RAL 5002 matt blue polyurethane, max temperature resistance 100°C in continuous, antistatic
<b>Cleats</b>	Blue polyurethane, max temperature resistance 100°C in continuous, 15°inclination; H20/35/50mm
<b>Drive</b>	Direct (left side)
<b>Gear Motor</b>	3 Phase – 400Vac/50Hz – 0.18Kw – asynchronous motor
<b>Speed</b>	3.2m/min.
<b>Load</b>	35kg
<b>Control</b>	IP55, thermal overload protected motor starter (on/off), emergency button, five cores (5x1.5mm) cable length 3000mm flame-retardant



PL MACHINERY SERVICES & SALES LTD  
UNIT A3/A4 BARTON INDUSTRIAL ESTATE, FALDO ROAD,  
BARTON LE CLAY, BEDFORDSHIRE, MK45 4RP

TEL: 01582 883666 / EMAIL: [sales@plmachinery.com](mailto:sales@plmachinery.com)